

Industrial Applications

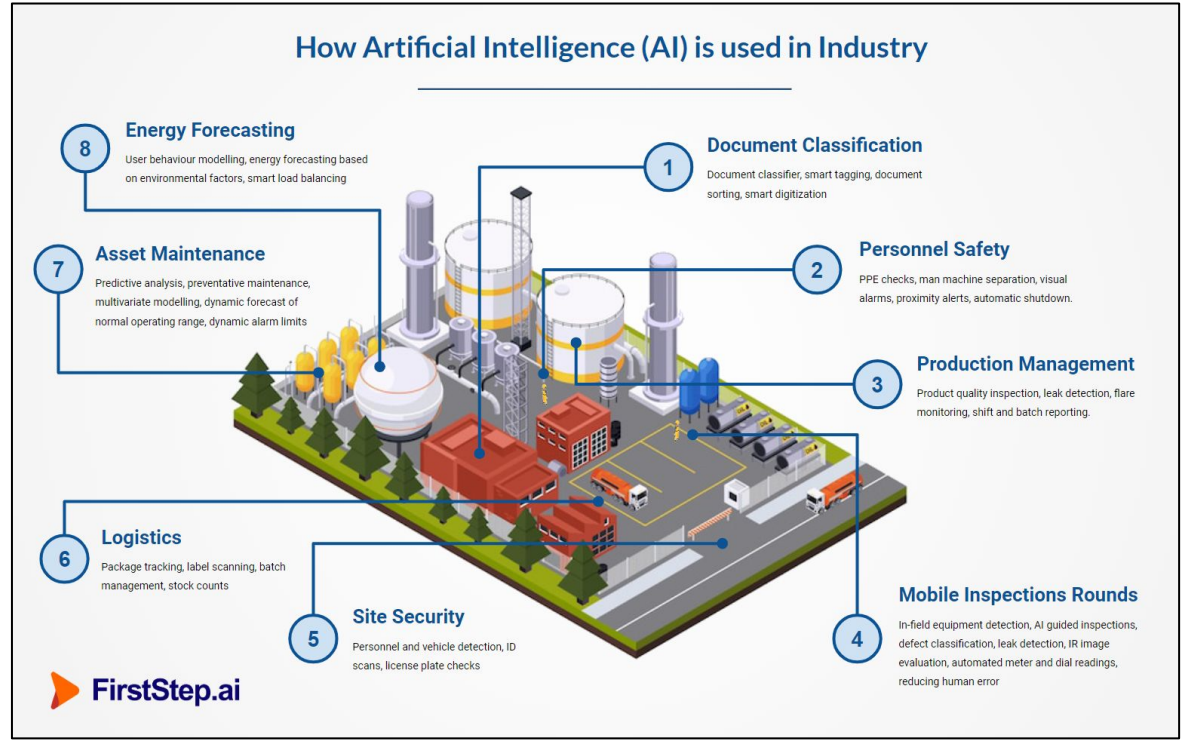

- 1 Document Classification
- 2 Personnel Safety
- 3 Production Management
- 4 Mobile Operator Inspections
- 5 Site Security
- 6 Logistics
- 7 Asset Maintenance
- 8 Energy Forecasting



- 1 Document Classification
- 2 Personnel Safety
- 3 Production Management
- 4 Mobile Operator Inspections
- 5 Site Security
- 6 Logistics
- 7 Asset Maintenance
- 8 Energy Forecasting

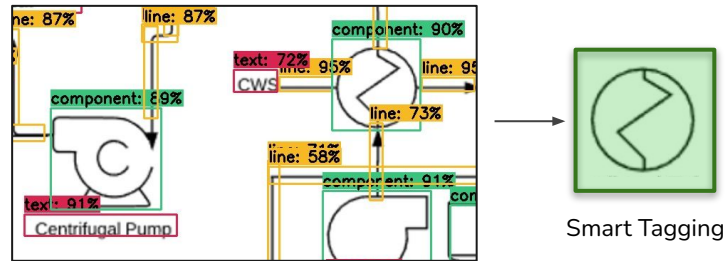
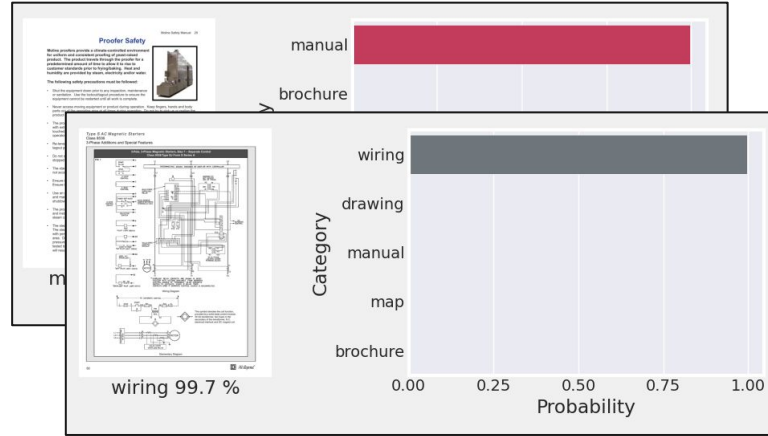

Applicable sectors:

- Industrial
- Financial
- Banking
- Insurance

Application:

- Server Application
- GPU Processor

- 1 Document Classification
- 2 Personnel Safety**
- 3 Production Management
- 4 Mobile Operator Inspections
- 5 Site Security
- 6 Logistics
- 7 Asset Maintenance
- 8 Energy Forecasting



Applicable areas:

Hazardous Areas

Access control

PPE checks

Equipment logs

Collision Avoidance

Application:

Hand-held Mobile

Edge IoT + camera

- 1 Document Classification
- 2 Personnel Safety
- 3 Production Management**
- 4 Mobile Operator Inspections
- 5 Site Security
- 6 Logistics
- 7 Asset Maintenance
- 8 Energy Forecasting

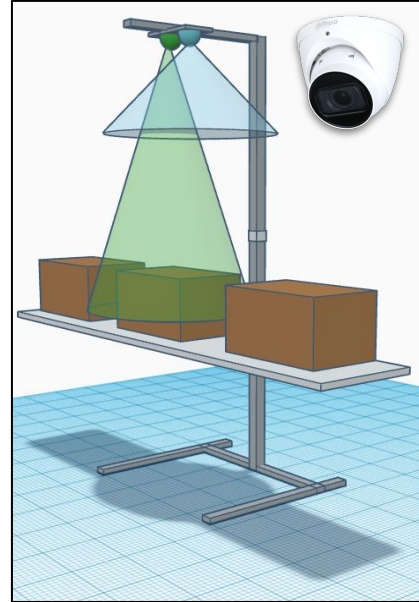
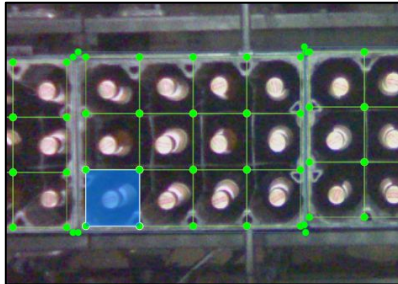

Applicable areas:

FMCG
Manufacturing
Breweries
Bottling

Application:

Edge IoT + camera
Server Application

- 1 Document Classification
- 2 Personnel Safety
- 3 Production Management
- 4 Mobile Operator Inspections**
- 5 Site Security
- 6 Logistics
- 7 Asset Maintenance
- 8 Energy Forecasting

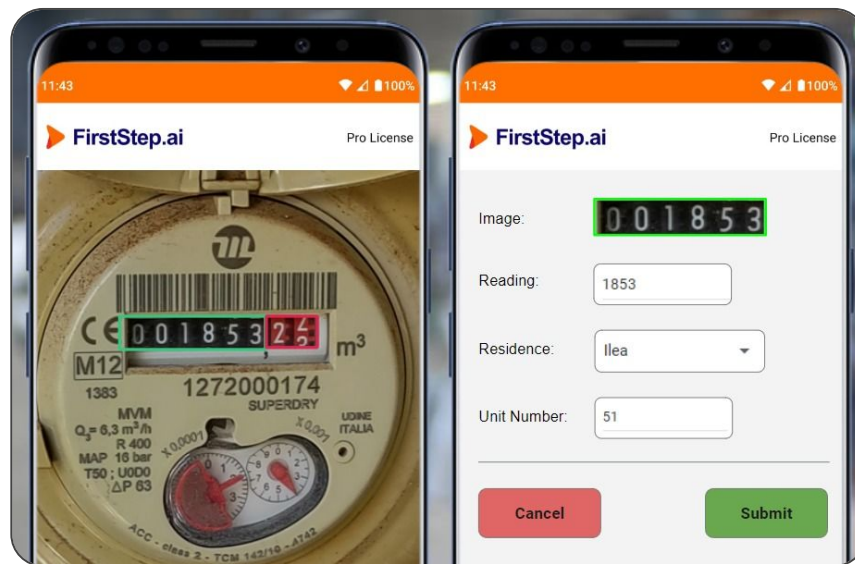

Applicable areas:

Industrial
Residential
Utilities
Oil & Gas

Application:

Mobile
Cloud Dashboard

- 1 Document Classification
- 2 Personnel Safety
- 3 Production Management
- 4 Mobile Operator Inspections
- 5 Site Security**
- 6 Logistics
- 7 Asset Maintenance
- 8 Energy Forecasting



Applicable areas:

Logistics
Loading Docks
Parking Garages
Road Monitoring
ANPR

Application:

Mobile
Edge IoT + Camera

- 1 Document Classification
- 2 Personnel Safety
- 3 Production Management
- 4 Mobile Operator Inspections
- 5 Site Security
- 6 Logistics**
- 7 Asset Maintenance
- 8 Energy Forecasting

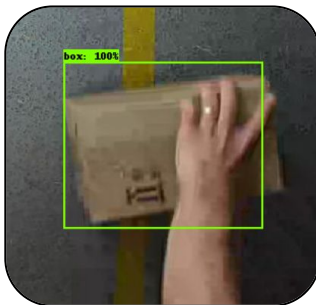

Applicable areas:

Logistics
Healthcare
Equipment
Shipping

Application:

Edge IoT + Camera
Cloud Dashboard

- 1 Document Classification
- 2 Personnel Safety
- 3 Production Management
- 4 Mobile Operator Inspections
- 5 Site Security
- 6 Logistics
- 7 Asset Maintenance**
- 8 Energy Forecasting

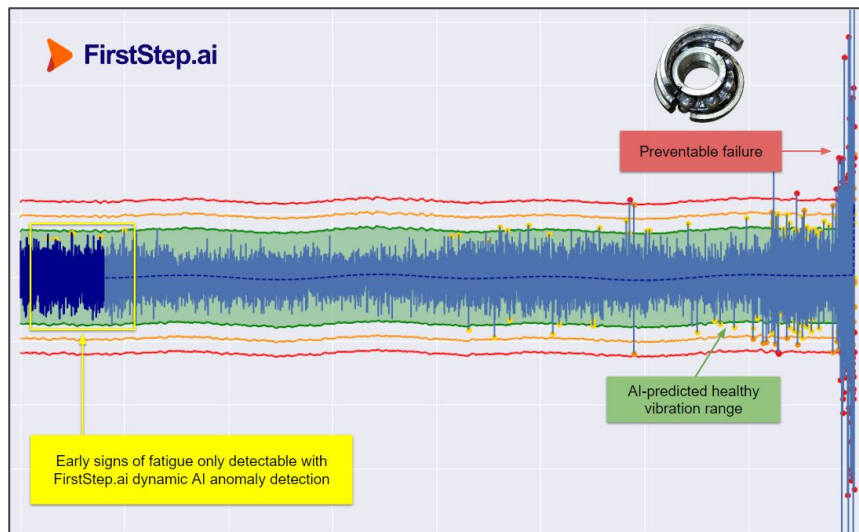

Applicable areas:

- Bearing Monitoring
- Predictive Maint.
- Anomaly Detection
- Safe Limits
- Alarms

Application:

- Edge IoT
- Server Application

- 1 Document Classification
- 2 Personnel Safety
- 3 Production Management
- 4 Mobile Operator Inspections
- 5 Site Security
- 6 Logistics
- 7 Asset Maintenance
- 8 Energy Forecasting**

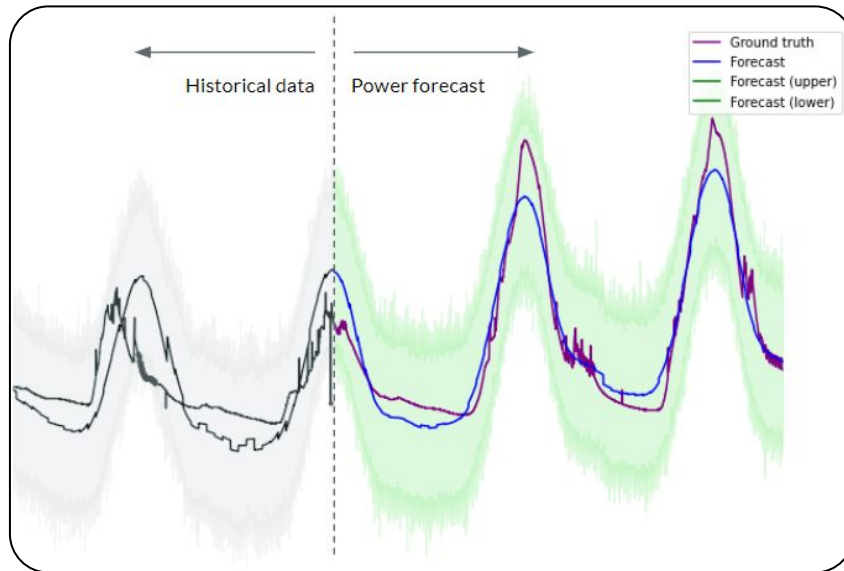

Applicable areas:

Utilities
Solar & Wind
Biogas
Desalination

Application:

Edge IoT
Server Application

Design in the cloud

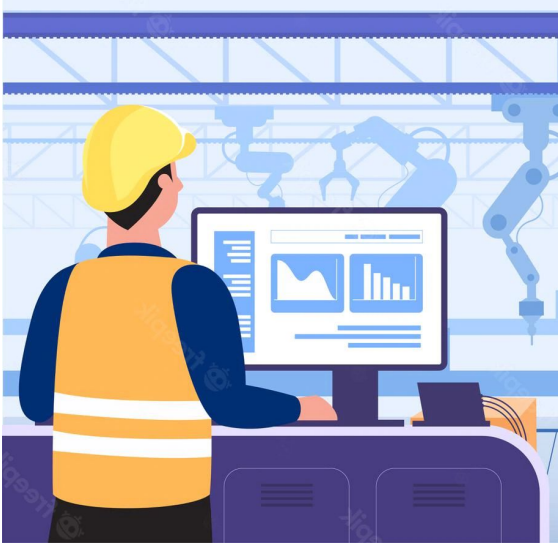

Deploy on-premise

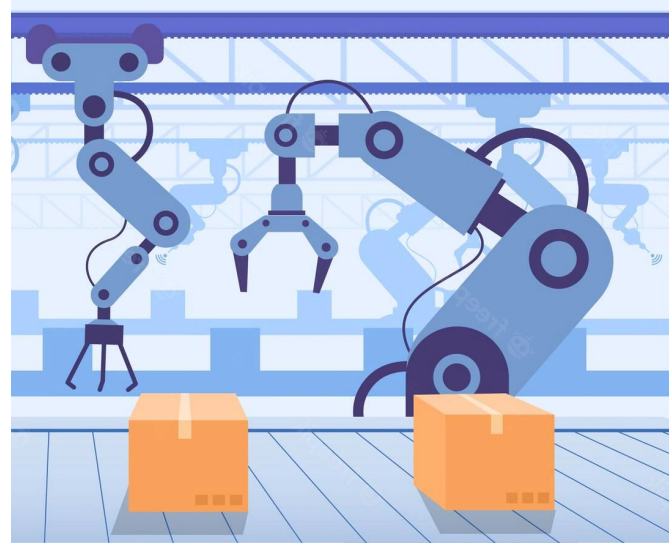

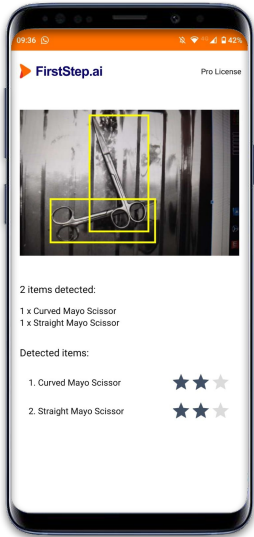

Mobile Phone

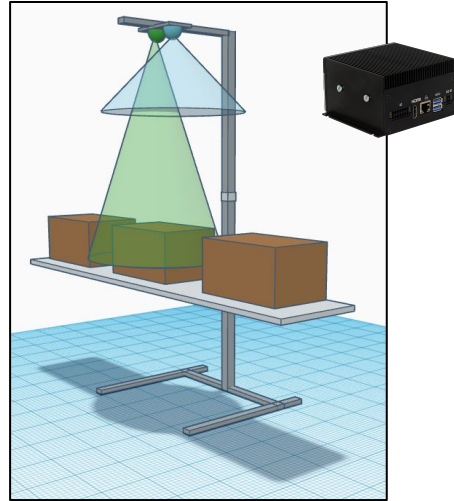

EDGE IoT (fixed)



Private Network



Cloud Server

▶ FirstStep.ai Designer

